

HINO 185 SERIES



2008

TRUCK CHASSIS SPECIFICATIONS

(NC6J) SS-NC015

GVW (M/T & A/T Allison) 8,170 kg (18,000 lbs)

GVW (A/T Aisin) 8,000 kg (17,600 lbs)

ENGINE MODEL: J05D-TF (Turbo Intercooled)

All 2008 models require ultra-low sulfur fuel

DIMENSIONS (On standard specifications)

MODEL		NC6JJSA		NC6JKSA		NC6JMSA	
Wheelbase	A mm(in.)	4,293	(169.0)	4,648	(183.0)	5,105	(201.0)
Overall length	B mm(in.)	6,772	(266.6)	7,432	(292.6)	7,889	(310.6)
Overall width	C mm(in.)	2,315	(91.1)	2,315	(91.1)	2,315	(91.1)
Overall height	D mm(in.)	2,575	(101.4)	2,575	(101.4)	2,575	(101.4)
Cab to axle	E mm(in.)	2,683	(105.6)	3,038	(119.6)	3,495	(137.6)
Rear overhang	F mm(in.)	1,600	(63.0)	1,905	(75.0)	1,905	(75.0)
Frame height at							
Front axle	G mm(in.)	760	(29.9)	760	(29.9)	760	(29.9)
Rear axle	H mm(in.)	865	(34.1)	865	(34.1)	865	(34.1)
Road clearance							
(at front axle)	J mm(in.)	180	(7.1)	180	(7.1)	180	(7.1)
Tread							
Front	K mm(in.)	1,850	(72.8)	1,850	(72.8)	1,850	(72.8)
Rear	L mm(in.)	1,825	(71.9)	1,825	(71.9)	1,825	(71.9)
Turning radius							
Tire	mm(in.)	7,010	(276.0)	7,530	(296.5)	8,200	(322.8)
Swept	mm(in.)	7,440	(292.9)	7,960	(313.4)	8,630	(339.8)

CHASSIS WEIGHTS (On std. spec., without spare tire & std. tool set)

MT	Total weight	kg(lb.)	3,325 (7,330)	3,345 (7,370)	3,365 (7,420)
	Front axle	kg(lb.)	2,170 (4,785)	2,190 (4,825)	2,215 (4,885)
	Rear axle	kg(lb.)	1,155 (2,545)	1,155 (2,545)	1,150 (2,535)
AT Aisin	Total weight	kg (lb)	3243 (7134)	3263 (7178)	3283 (7222)
	Front axle	kg (lb)	2121 (4666)	2141 (4710)	2166 (4765)
	Rear axle	kg (lb)	1122 (2468)	1122 (2468)	1117 (2457)
AT Allison	Total weight	kg(lb.)	3,365 (7,420)	3,385 (7,460)	3,405 (7,510)
	Front axle	kg(lb.)	2,205 (4,610)	2,225 (4,905)	2,255 (4,975)
	Rear axle	kg(lb.)	1,160 (2,555)	1,160 (2,555)	1,150 (2,535)

POWER LINE & PERFORMANCE [8,170 kg (18,000 lbs.) GVW & 225-70R19.5 tires]

Power line	□ STD.	□ OPT.	□ OPT.
Max. speed km/h	124	114	128
Gradeability (tan.θ) %	46.6	55.3	51.0
Transmission Model	Eaton FS4205A	AISIN 450-43LE	ALLISON 1000HS
Type	Five-speed direct drive synchromesh 2nd-5th	Four-speed automatic	Five-speed automatic
1st.	8.052	3.018	3.102
2nd.	4.352	1.548	1.811
3rd.	2.448	1.000	1.406
Ratios	4th.	0.703	1.000
5th.	1.000	—	0.712
Rev.	8.052	2.678	4.492
Rear axle gear ratios	3.580	5.570	4.880

ENGINE

Model	HINO J05D-TF
Type:	Diesel 4-cy., 4-cyl. in-line, water-cooled
Combustion system:	Direct injection type
Max. output:	175HP (SAE Gross) at 2,500 rpm
Max. torque:	510 N·m (SAE Gross) (376 lb.-ft.) at 1,600 rpm
Bore and stroke:	112 x 120 mm (4.41 x 4.72 in.)
Piston displacement:	4.730 L (288.5 cu.in.)
Fuel injection system:	Common rail ND
Governor:	Electronically controlled
Intake system:	Turbocharged and intercooled
Air cleaner:	Paper filter type ("DONALDSON")
Pre-heater:	Glow plug type
Fan clutch:	Bimetal thermostat sensor regulates fan speed
Block heater:	1,000 watts/120V immersion type

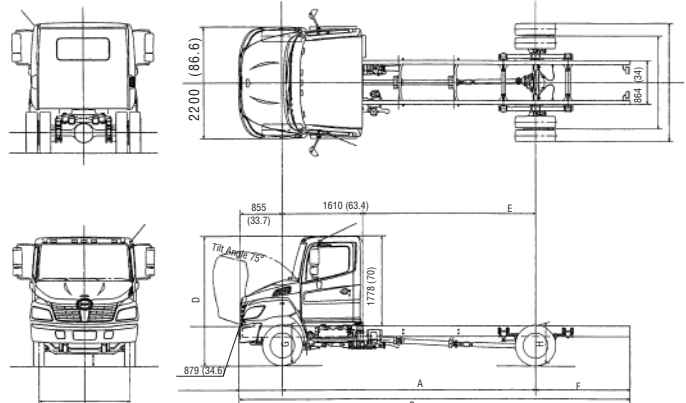

THE QUALITY CHOICE.

www.hinocanada.com

WEIGHT CAPACITIES

Front axle	kg(lbs.)	2,830 (6,250)
Rear axle	kg(lbs.)	5,900 (13,000)
Front spring	kg(lbs.)	2,720 (6,000)
Rear spring	kg(lbs.)	5,900 (13,000)

LIQUID CAPACITIES

Fuel tank ltr.(gal./US)	132.5 (35)
Cooling system	20.0 (5.29)
ltr.(gal./US)	: Eaton FS4205A 19.5 (5.16) : AISIN 450-43LE 19.5 (5.16) : ALLISON 1000HS

AXLE / SUSPENSION

Front axle	MFS-6 series reversed Elliot, "I" beam
Front spring	Taper-leaf springs w/ shock absorbers
Rear axle	RS13-120 series Full-floating, single reduction Single-speed by hypoid gearings
Rear spring	Aisin A/T: Semi-elliptic main Allison A/T & Eaton M/T : Semi-elliptic main and auxiliary helper, w/ shock absorbers

FRAME

Ladder type	Straight J section
Width mm(in.)	863.6 (34)
Tensile strength kg/mm ² (lb/in) ²	63.4 (90,143)
Resisting bending moment (one side)	754,691 (655,100) no reinforcement
	kg•cm (in•lbs.)

STEERING

Type	Telescopic and tilt steering column with lock Recirculating ball, with hydraulic booster integral type
------	---

CLUTCH

Type	Dry single plate with damper springs EATON-SPICER AR350 series
Facing material	Cerametallic
Facing outside diameter mm (in.)	350 (13.8)
Control	Hydraulic

WHEELS / TIRES

Wheel size	19.5X6.00RW, 8 stud
w/Eaton M/T & Allison A/T:	6 steel wheels
w/Aisin A/T:	6 aluminum wheels
Tires	225/70/19.5
Brand & Pattern	BS Fr: RIB, Rr: LUG

BRAKES

Service brake	Hydraulic system with disc brake for front and rear wheels, with automatic adjustment
Disc diameter	Front;
x pad area (cm ²)	324 x 110 x 15.5
x thickness	(12.756 x 17.05 x 0.61)
mm(in.)	Rear; 390.5 x 122.3 x 18.8 (15.375 x 18.96 x 0.74)
Control	Hydraulic dual circuit with Antilock Brake System(ABS)
Parking brake	Mechanical, internal (with cover) expanding acting on transmission output shaft
Drum diameter mm(in.)	254 (10): MERITOR 10 228.6 (9): BOSCH 9
Exhaust brake	Electric-pneumatic with valve in exhaust pipe

CAB EQUIPMENT

Cab construction	- All steel welded
Seating	- Three Driver's seat - Adjustable reclining, covered with fabric with coil suspension Passenger's seat - Bench type, covered with fabric
Seat belts	- 3-point type (driver and passenger), one 2-point type (centre)
Heater/Defroster	- 18,357 BTU/h (4,627 Kcal/h)
Mirrors outside rearview	- heated - 1 flat and 1 convex on each side
Sun visors	- Two
Over-head console	- Two
Air conditioning	
Windshield	- Laminated
Windshield wipers	- Dual electric, 2-speed and intermittent
Cup holder	- L size (centre console)
Cup holder at centre cluster	(Single) for MT
Cup holder at centre cluster	(Dual) for AT
Electric power windows	
Electronic cruise control	
Cigarette lighter	

DASH INSTRUMENTATION

Driver information display	
Meters and gauges, metric system	
Speedometer	- km/h (mph)
Odometer	(km/h)
Fuel gauge	
Coolant temperature gauge	
Engine tachometer	
Warning and pilot lamps and buzzers	
Oil pressure warning lamp and buzzer	
Brake pressure warning lamp and buzzer	
Coolant level warning lamp and buzzer	
Battery charging warning lamp	
High beam indicator lamp	
Turn signal pilot lamp	
Parking brake warning lamp	
Engine control system warning lamp	
ABS warning lamp	
Glow plug pre-heater indicator lamp	

ELECTRICAL EQUIPMENT

Batteries	Two, parallel connection, each 12 V
Capacity	1200 CCA
Alternator	12 V, 105 A brushless
Starter	12 V, 2.5 kW
Audio system	AM/FM radio with CD
Headlamps	2, composite type
Identification lamps (front)	LED type
Stop/Tail lamps	
Back-up lamps	
Turn signals and hazard warning lamps	
Dome lamp	
Front side marker lamps	
Clearance lamps (front)	
Electrical horn	(dual)

CHASSIS EQUIPMENT

Fuel pre-filter	- Pre-filter (dust) and sedimenter (water) with heater
Reflectors	- Two rear, two front side
Hook	- One at front
Radiator Grille	Chrome

See your authorized Hino Dealer for a complete list of options and accessories.

NOTE : All specifications of the products are with normal manufacturing allowances and tolerances.
HINO MOTORS CANADA, LTD. reserves the right to alter specifications at any time without previous notice.