

HINO 258 SERIES



HINO

2008

TRUCK CHASSIS SPECIFICATIONS

(ND8J Lo-Pro) SS-ND021

GVW: 11,570 kg (25,500 lbs.)

ENGINE MODEL: J08E-TV (Turbo Intercooled)

All 2008 models require ultra-low sulfur fuel

DIMENSIONS (On standard specifications)

MODEL		ND8JISA	ND8JLSA	ND8JMSA	ND8JPSA	ND8JRSA	ND8JTSA
Wheelbase	A mm(in.)	4,445 (175.0)	4,750 (187.0)	5,207 (205.0)	5,512 (217.0)	5,969 (235.0)	6,426 (253.0)
Overall length	B mm(in.)	7,076 (278.6)	7,686 (302.6)	8,143 (320.6)	9,007 (354.6)	9,464 (372.6)	9,921 (390.6)
Overall width	C mm(in.)	2,430 (95.7)	2,430 (95.7)	2,430 (95.7)	2,430 (95.7)	2,430 (95.7)	2,430 (95.7)
Overall height	D mm(in.)	2,605 (102.6)	2,605 (102.6)	2,605 (102.6)	2,605 (102.6)	2,605 (102.6)	2,605 (102.6)
Cab to axle	E mm(in.)	2,733 (107.6)	3,038 (119.6)	3,495 (137.6)	3,800 (149.6)	4,257 (167.6)	4,714 (185.6)
Rear overhang	F mm(in.)	1,600 (63.0)	1,905 (75.0)	1,905 (75.0)	2,464 (97.0)	2,464 (97.0)	2,464 (97.0)
Frame height at							
Front axle	G mm(in.)	830 (32.7)	830 (32.7)	830 (32.7)	830 (32.7)	830 (32.7)	830 (32.7)
Rear axle	H mm(in.)	905 (35.6)	905 (35.6)	905 (35.6)	905 (35.6)	905 (35.6)	905 (35.6)
Road clearance							
(at front axle)	J mm(in.)	180 (7.1)	180 (7.1)	180 (7.1)	180 (7.1)	180 (7.1)	180 (7.1)
Tread							
Front	K mm(in.)	2,020 (79.5)	2,020 (79.5)	2,020 (79.5)	2,020 (79.5)	2,020 (79.5)	2,020 (79.5)
Rear	L mm(in.)	1,845 (72.6)	1,845 (72.6)	1,845 (72.6)	1,845 (72.6)	1,845 (72.6)	1,845 (72.6)
Turning radius							
Tire	mm(in.)	7,310 (287.8)	7,760 (305.6)	8,430 (331.9)	8,880 (349.7)	9,550 (376.)	10,220 (402.4)
Swept	mm(in.)	7,820 (307.9)	8,270 (325.6)	8,940 (352.0)	9,390 (369.7)	10,060 (396.1)	10,730 (422.4)

CHASSIS WEIGHTS (On std. spec., without spare tire & std. tool set)

MT Total weight	kg(lb.)	4,145 (9,140)	4,175 (9,200)	4,225 (9,310)	4,275 (9,420)	4,310 (9,500)	4,325 (9,530)
Front axle	kg(lb.)	2,675 (5,900)	2,695 (5,935)	2,740 (6,035)	2,750 (6,060)	2,785 (6,140)	2,805 (6,180)
Rear axle	kg(lb.)	1,470 (3,240)	1,480 (3,265)	1,485 (3,275)	1,525 (3,360)	1,525 (3,360)	1,520 (3,350)
AT Total weight	kg(lb.)	4,120 (9,080)	4,145 (9,140)	4,195 (9,250)	4,250 (9,370)	4,280 (9,440)	4,295 (9,470)
Front axle	kg(lb.)	2,640 (5,815)	2,655 (5,855)	2,700 (5,955)	2,715 (5,985)	2,750 (6,065)	2,770 (6,110)
Rear axle	kg(lb.)	1,480 (3,265)	1,490 (3,285)	1,495 (3,295)	1,535 (3,385)	1,530 (3,375)	1,525 (3,360)

POWER LINE & PERFORMANCE

[11,570 kg (25,500 lbs.) GVW & 245/70R19.5 tires]

Power line	STD.	OPT.
Max. speed km/h	130	136
Gradeability (tan.θ) %	41.6	31.9
Transmission Model	Eaton FS5406A	Allison 2200 RDS
Type	Five-speed direct drive synchromesh 2nd-6th	Five-speed automatic
1st.	9.008	3.102
2nd.	5.270	1.811
3rd.	3.220	1.406
Ratios	2.040	1.000
4th.	2.040	1.000
5th.	1.361	0.712
6th.	1.000	-
Rev.	8.625	4.492
Rear axle gear ratios	3.070	4.110
Tire is combined with ratio	245/70R19.5(G)	245/70R19.5(G)

ENGINE

Model	HINO J08E-TV
Type:	Diesel 4-cy., 6-cyl. in-line, water-cooled
Combustion system:	Direct injection type
Max. output: (SAE Gross)	220HP at 2,500 rpm
Max. torque: (SAE Gross)	706 N·m (520 lb.-ft.) at 1,500 rpm
Bore and stroke:	112 x 130 mm (4.41 x 5.12 in.)
Piston displacement	7.680 L (468.8 cu.in.)
Fuel injection system:	Common rail ND
Governor:	Electronically controlled
Intake system:	Turbocharged and intercooled
Air cleaner:	Paper filter type ("DONALDSON")
Pre-heater:	Glow plug type
Fan clutch:	Bimetal thermostat sensor regulates fan speed
Block heater:	1,000 watts/120V immersion type

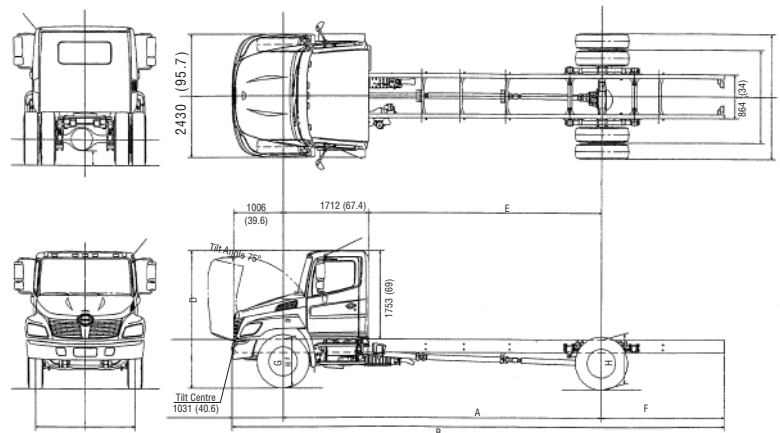

THE QUALITY CHOICE.

www.hinocanada.com

WEIGHT CAPACITIES

Front axle	kg (lbs.)	3,630 (8,000)
Rear axle	kg (lbs.)	7,940 (17,500)
Front spring	kg (lbs.)	3,630 (8,000)
Rear spring	kg (lbs.)	8,620 (19,000)

LIQUID CAPACITIES

Fuel tank ltr.(gal./US)	196.8 (52)
Cooling system	23.5 (6.21)
ltr.(gal./US)	: Eaton FS5406A
	23.0 (6.08)
	: ALLISON 2200 RDS

AXLE / SUSPENSION

Front axle	MFS-8 series reversed Elliot, "I" beam, Oil lubricated front wheel bearings
Front spring	Taper-leaf springs w/ shock absorbers
Rear axle	RS17-145 series Full-floating, single reduction Single-speed by hypoid gearings oil-lubricated type
Rear spring	Semi-elliptic main and auxiliary helper

FRAME

Ladder type	Straight] section
Width mm(in.)	863.6 (34)
Tensile strength kg/mm ² (lb/in) ²	63.4 (90,143)
Resisting bending moment (one side) kgf•cm (in•lbs.)	1,188,862 (1,031,900) no reinforcement

STEERING

Type	Telescopic and tilt steering column with lock Recirculating ball, with hydraulic booster integral type
------	--

CLUTCH

Type	Dry single plate self-adjusting EATON-SPICER Solo 1401 series
Facing material	Cerametallic
Facing outside diameter mm (in.)	350 (13.8)
Control	Hydraulic

WHEELS / TIRES

6 Wheels	19.5X6.75 8-stud disc.
6 Tires	245/70R19.5(G)
Brand & Pattern	BS Fr: RIB, Rr: LUG

BRAKES

Service brake	Hydraulic system with disc brake for front and rear wheels, with automatic adjustment
Disc diameter	Front;
x pad area (cm ²)	390.5 x 122.3 x 18.8
x thickness	(15.375 x 18.96 x 0.74)
mm(in.)	Rear;
	390.5 x 122.3 x 18.8
	(15.375 x 18.96 x 0.74)
Control	Hydraulic dual circuit with Antilock Brake System(ABS)
Parking brake	Mechanical, internal expanding acting on transmission output shaft
Drum diameter	304.8 (12): MERITOR12
mm(in.)	228.6 (9): BOSCH 9
Exhaust brake	Electric-pneumatic with valve in exhaust pipe

CAB EQUIPMENT

Cab construction	- All steel welded
Seating	- Three
	Driver's seat - Adjustable reclining, covered with fabric
	Passenger's seat - Bench type, covered with fabric
Seat belts	- 3-point type (driver and passenger), one 2-point type (centre)
Heater/Defroster	- 18,357 BTU/h (4,627 Kcal/h)
Mirrors outside rearview	- heated - 1 flat and 1 convex on each side
Sun visors	- Two
Over-head console	- Two
Air conditioning	
Windshield	- Laminated
Windshield wipers	- Dual electric, 2-speed and intermittent
Cup holders, dash and console mounted	
Electric power windows	
Electronic cruise control	
Cigarette lighter	

DASH INSTRUMENTATION

Driver information display	
Meters and gauges, metric system	
Speedometer	- km/h (mph)
Odometer	(km/h)
Fuel gauge	
Coolant temperature gauge	
Engine tachometer	
Warning and pilot lamps and buzzers	
Oil pressure warning lamp and buzzer	
Coolant level warning lamp and buzzer	
Battery charging warning lamp	
High beam indicator lamp	
Turn signal pilot lamp	
Parking brake warning lamp	
Engine control system warning lamp	
ABS warning lamp	
Glow plug pre-heater indicator lamp	

ELECTRICAL EQUIPMENT

Batteries	Two, parallel connection, each 12 V
Capacity	1200 CCA
Alternator	12 V, 105 A brushless
Starter	12 V, 4.0 kW
Audio system	AM/FM radio with CD
Headlamps	2, composite type
Identification lamps (front) LED type	
Stop/Tail lamps	
Back-up lamps	
Turn signals and hazard warning lamps	
Dome lamp	
Front side marker lamps	
Clearance lamps (front)	
Electrical horn (dual)	

CHASSIS EQUIPMENT

Fuel pre-filter	- Pre-filter (dust) and sedimenter (water) with heater, Davco
Reflectors	- Two rear, two front side
Hook	- One at front
Radiator Grille, Chrome	
Bumper, 3 piece front	

See your authorized Hino Dealer for a complete list of options and accessories.

NOTE : All specifications of the products are with normal manufacturing allowances and tolerances. HINO MOTORS CANADA, LTD. reserves the right to alter specifications at any time without previous notice.