

# HINO 268 SERIES



# 2008

## TRUCK CHASSIS SPECIFICATIONS

(NE8J) SS-NEO14

GVW: 11,818 kg (26,000 lbs.)

ENGINE MODEL: J08E-TV (Turbo Intercooled)

All 2008 models require ultra-low sulfur fuel

### DIMENSIONS (On standard specifications)

MODEL		NE8JMSA	NE8JPSA	NE8JRSA	NE8JTSA
Wheelbase	A mm(in.)	5,207 (205.0)	5,512 (217.0)	5,969 (235.0)	6,426 (253.0)
Overall length	B mm(in.)	8,143 (320.6)	9,007 (354.6)	9,464 (372.6)	9,921 (390.6)
Overall width	C mm(in.)	2,445 (96.3)	2,445 (96.3)	2,445 (96.3)	2,445 (96.3)
Overall height	D mm(in.)	2,710 (106.7)	2,710 (106.7)	2,710 (106.7)	2,710 (106.7)
Cab to axle	E mm(in.)	3,495 (137.6)	3,800 (149.6)	4,257 (167.6)	4,714 (185.6)
Rear overhang	F mm(in.)	1,905 (75.0)	2,464 (97.0)	2,464 (97.0)	2,464 (97.0)
Frame height at					
Front axle	G mm(in.)	935 (36.8)	935 (36.8)	935 (36.8)	935 (36.8)
Rear axle	H mm(in.)	1,010 (39.8)	1,010 (39.8)	1,010 (39.8)	1,010 (39.8)
Road clearance					
(at front axle)	J mm(in.)	285 (11.2)	285 (11.2)	285 (11.2)	285 (11.2)
Tread					
Front	K mm(in.)	1,980 (78.0)	1,980 (78.0)	1,980 (78.0)	1,980 (78.0)
Rear	L mm(in.)	1,830 (72.0)	1,830 (72.0)	1,830 (72.0)	1,830 (72.0)
Turning radius					
Tire	mm(in.)	8,410 (331.1)	8,860 (348.8)	9,530 (375.2)	10,200 (401.6)
Swept	mm(in.)	8,940 (352.0)	9,390 (369.7)	10,060 (396.1)	10,730 (422.4)

### CHASSIS WEIGHTS (On std. spec., without spare tire & std. tool set)

		NE8JMSA	NE8JPSA	NE8JRSA	NE8JTSA
MT Total weight	kg(lb.)	4,375 (9,650)	4,425 (9,760)	4,455 (9,820)	4,475 (9,870)
Front axle	kg(lb.)	2,795 (6,165)	2,805 (6,190)	2,835 (6,250)	2,860 (6,310)
Rear axle	kg(lb.)	1,580 (3,485)	1,620 (3,570)	1,620 (3,570)	1,615 (3,560)
AT Total weight	kg(lb.)	4,345 (9,580)	4,395 (9,690)	4,430 (9,770)	4,445 (9,800)
Front axle	kg(lb.)	2,755 (6,075)	2,765 (6,095)	2,800 (6,175)	2,825 (6,230)
Rear axle	kg(lb.)	1,590 (3,505)	1,630 (3,595)	1,630 (3,595)	1,620 (3,570)

### POWER LINE & PERFORMANCE

[11,818 kg (26,000 lbs.) GVW & 11.00R22.5-14 tires]

Power line	□ STD.	□ OPT.	□ STD.	□ OPT.
Max. speed km/h	121	125	126	127
Gradeability (tan.θ) %	44.2	42.7	34.3	33.8
Transmission Model	Eaton FS5406A		Allison 2200 RDS	
Type	Six-speed direct drive synchronesh 1st-6th		Five-speed automatic	
1st.	9.008		3.102	
2nd.	5.270		1.811	
3rd.	3.220		1.406	
4th.	2.040		1.000	
5th.	1.361		0.712	
6th.	1.000		-	
Rev.	8.625		4.492	
Rear axle gear ratios	4.110	3.730	5.570	5.130
Tire is combined with ratio	11R22.5-14	255/80R22.5	11R22.5-14	255/80R22.5

### ENGINE

Model	HINO J08E-TV
Type:	Diesel 4-cy., 6-cyl. in-line, water-cooled
Combustion system:	Direct injection type
Max. output: (SAE Gross)	220HP at 2,500 rpm
Max. torque: (SAE Gross)	706 N·m (520 lb.-ft.) at 1,500 rpm
Bore and stroke:	112 x 130 mm (4.41 x 5.12 in.)
Piston displacement	7.680 L (468.8 cu.in.)
Fuel injection system:	Common rail ND
Governor:	Electronically controlled
Intake system:	Turbocharged and intercooled
Air cleaner:	Paper filter type ("DONALDSON")
Fan clutch:	Bimetal thermostast sensor regulates fan speed
Block heater:	1,000 watts/120V immersion type

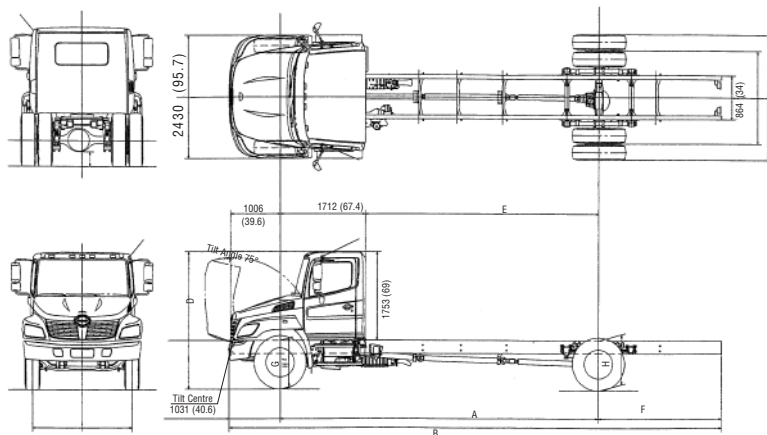

THE QUALITY CHOICE.

**WEIGHT CAPACITIES**

Front axle	kg(lbs.)	4,540 (10,000)
Rear axle	kg(lbs.)	8,620 (19,000)
Front spring	kg(lbs.)	5,440 (12,000)
Rear spring	kg(lbs.)	8,620 (19,000)

**LIQUID CAPACITIES**

Fuel tank ltr.(gal./US)	196.8 (52)
Cooling system	23.5 (6.21)
ltr.(gal./US)	: Eaton FS5406A
	23.0 (6.08)
	: ALLISON 2200RDS

**AXLE / SUSPENSION**

Front axle	MFS-10 series reversed Elliot, "I" beam, Oil lubricated front wheel bearings
Front spring	Taper-leaf springs w/ shock absorbers
Rear axle	RS19-145 series Full-floating, single reduction Single-speed by hypoid gears
Rear spring	Semi-elliptic main and auxiliary helper, -leaf spring

**FRAME**

Ladder type	Straight ] section
Width mm(in.)	863.6 (34)
Tensile strength kg/mm <sup>2</sup> (lb/in) <sup>2</sup>	63.4 (90,143)
Resisting bending moment (one side)	1,188,862 (1,031,900) no reinforcement
	kgf•cm (in•lbs.)

**STEERING**

Type	Telescopic and tilt steering column with lock Recirculating ball, with hydraulic booster integral type
------	--

**CLUTCH**

Type	Dry single plate self-adjusting EATON-SPICER Solo 1401 series
Facing material	Cerametallic
Facing outside diameter mm (in.)	350 (13.8)
Control	Hydraulic

**WHEELS / TIRES**

6 Wheels	22.5X8.25, 10-stud disc.
6 Tires	11R22.5(G)
Brand & Pattern	BS Fr: RIB, Rr: LUG

**BRAKES**

Service brake	Hydraulic system with disc brake for front and rear wheels, with automatic adjustment
Disc diameter	Front;
x pad area (cm <sup>2</sup> )	390.5 x 122.3 x 18.8
x thickness	(15.375 x 18.96 x 0.74)
mm(in.)	Rear;
	390.5 x 122.3 x 18.8
	(15.375 x 18.96 x 0.74)
Control	Hydraulic dual circuit with Antilock Brake System(ABS)
Parking brake	Mechanical, internal expanding acting on transmission output shaft
Drum diameter	304.8 (12): MERITOR 12
mm(in.)	228.6 (9): BOSCH 9
Exhaust brake	Electric-pneumatic with valve in exhaust pipe

**CAB EQUIPMENT**

Cab construction	- All steel welded
Seating	- Three
Driver's seat	- Adjustable reclining, covered with fabric with coil suspension
Passenger's seat	- Bench type, covered with fabric
Seat belts	- 3-point type (driver and passenger), one 2-point type (centre)
Heater/Defroster	- 18,357 BTU/h (4,627 Kcal/h)
Mirrors outside rearview	- heated - 1 flat and 1 convex on each side
Sun visors	- Two
Over-head console	- Two
Air conditioning	
Windshield	- Laminated
Windshield wipers	- Dual electric, 2-speed and intermittent
Cup holder	- L size (centre console)
Cup holders, dash and console mounted	
Electric power windows	
Electronic cruise control	
Cigarette lighter	

**DASH INSTRUMENTATION**

Driver information display
Meters and gauges, metric system
Speedometer - km/h (mph)
Odometer (km/h)
Fuel gauge
Coolant temperature gauge
Engine tachometer
Warning and pilot lamps and buzzers
Oil pressure warning lamp and buzzer
Brake pressure warning lamp and buzzer
Coolant level warning lamp and buzzer
Battery charging warning lamp
High beam indicator lamp
Turn signal pilot lamp
Parking brake warning lamp
Engine control system warning lamp
ABS warning lamp

**ELECTRICAL EQUIPMENT**

Batteries	Two, parallel connection, each 12 V
Capacity	1200 CCA
Alternator	12 V, 105 A brushless
Starter	12 V, 4.8 kW
Audio system	AM/FM radio with CD
Headlamps	2, composite type
Identification lamps (front)	
Stop/Tail lamps	
Back-up lamps	
Turn signals and hazard warning lamps	
Dome lamp	
Front side marker lamps	
Clearance lamps (front) LED type	
Electrical horn (dual)	

**CHASSIS EQUIPMENT**

Fuel pre-filter - Pre-filter (dust) and sedimenter (water) with heater	- DAVCO
Reflectors	- Two rear, two front side
Hook	- One at front
Bumper	- 3 piece front
Radiator Grille	- Chrome

*See your authorized Hino Dealer for a complete list of options and accessories.*

**NOTE :** All specifications of the products are with normal manufacturing allowances and tolerances.

HINO MOTORS CANADA, LTD. reserves the right to alter specifications at any time without previous notice.